

CM5A H21 SERIES

Current Sensor

Model Number:

CM5A 2000 H21

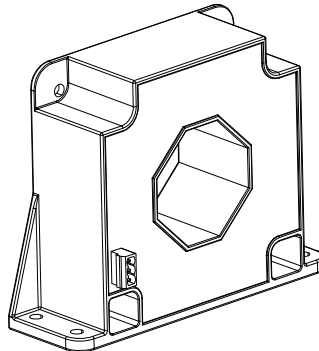

For the electronic measurement of current: DC, AC, pulsed..., with galvanic insulation between the primary and the secondary circuits.

Features

- ✧ Closed loop (compensated) current sensor using the Hall effect
- ✧ Galvanic insulation between primary and secondary
- ✧ Insulating plastic case recognized according to UL 94-V0
- ✧ Very good linearity
- ✧ High accuracy
- ✧ Very low offset drift over temperature
- ✧ No insertion loss
- ✧ Standards:
 - IEC 60664-1:2020
 - IEC 61800-5-1:2022
 - IEC 62109-1:2010

Applications

- ✧ Windmill inverter
- ✧ AC variable speed and servo motor drives
- ✧ Uninterruptible Power Supplies (UPS)
- ✧ Static converters for DC motor drives
- ✧ Switch Mode Power Supplies (SMPS)
- ✧ Power supplies for welding applications
- ✧ Battery management
- ✧ Wind energy inverter
- ✧ Test and detection devices

Safety

This sensor must be used according to IEC 61800-5-1.

This sensor must be used in electric/electronic equipment with respect to applicable standards and safety requirements in accordance with the following manufacture's operating instructions.

Caution, risk of electrical shock!



When operating the sensor, certain parts of the module can carry hazardous voltage (e.g., Primary busbar, power supply). Ignore this warning can lead to injury and/or cause serious damage.

This sensor is a built-in device, whose conducting parts must be inaccessible after installation. A protective housing or additional shield could be used.

Main supply must be able to be disconnected.

CM5A H21 SERIES

Absolute maximum ratings(not operating)

Parameter	Symbol	Unit	Value
Supply voltage	V_C	V	± 25.2
Primary conductor temperature	T_B	°C	100
Max. primary nominal current (-40...85°C)	I_{PN}	A	2000

- ※ Stresses above these ratings may cause permanent damage.
- ※ Exposure to absolute maximum ratings for extended periods may degrade reliability.

Environmental and mechanical characteristics

Parameter	Symbol	Unit	Min	Typ	Max	Comment
Ambient operating temperature	T_A	°C	-40		85	
Ambient storage temperature	T_S	°C	-40		90	
Mass	m	g		1500		

Insulation coordination

Parameter	Symbol	Unit	Value	Comment
Rms voltage for AC insulation test @ 50Hz, 1min	V_d	kV	6	According to IEC 60664-1
Impulse withstand voltage 1.2/50µs	V_w	kV	23	According to IEC 60664-1
Clearance (pri.- sec.)	d_{cl}	mm	28	
Creepage distance (pri.- sec.)	d_{cp}	mm	30	
Plastic case	-	-	UL94-V0	
Comparative tracking index	CTI	PLC	3	
Application example	-	-	2000V	Reinforced insulation, according to IEC 61800-5-1, IEC 62109-1CATIII, PD2
Application example	-	-	4000V	Basic insulation, according to IEC 61800-5-1, IEC 62109-1CATIII, PD2

CM5A H21 SERIES

Electrical data

※ With $T_A = 25^\circ\text{C}$, $V_C = \pm 24\text{V}$, $R_M = 1\Omega$, unless otherwise noted.

Parameter	Symbol	Unit	Min	Typ	Max	Comment
Primary nominal rms current	I_{PN}	A	-2000		2000	
Primary current, measuring range	I_{PM}	A	-4250		4250	
Measuring resistance	R_M	Ω	0		8	@ $\pm 15\text{V}$, 85°C , $\pm 2000\text{A}$
			0		1	@ $\pm 15\text{V}$, 85°C , $\pm 2500\text{A}$
			0		29	@ $\pm 24\text{V}$, 85°C , $\pm 2000\text{A}$
			0		1	@ $\pm 24\text{V}$, 85°C , $\pm 4250\text{A}$
Secondary nominal rms current	I_{SN}	mA	-400		400	
Secondary coil resistance	R_S	Ω		18		@ 25°C
Secondary current, measuring range	I_S	mA	-850		850	
Number of secondary turns	N_S	-		5000		
Theoretical sensitivity	G_{th}	mA/A		0.2		
Supply voltage	V_C	V	± 15		± 24	@ $\pm 5\%$
Current consumption	I_C	mA		38		
Zero offset current	I_0	mA	-0.5		0.5	
Thermal drift of offset current	I_{OT}	mA	-0.5		0.5	@ $-40^\circ\text{C} \sim 85^\circ\text{C}$
Residual current@ $I_P=0$ after I_{PN}	I_{OM}	mA	-0.2		0.2	
Sensitivity error	ε_G	%	-0.2		0.2	Exclusive of I_{OE}
Linearity error 0... I_{PN}	ε_L	% of I_{PN}	-0.1		0.1	Exclusive of I_{OE}
Accuracy@ I_{PN}	χ	% of I_{PN}	-0.3		0.3	Exclusive of I_{OE}
Response time@ 90% of I_{PN}	t_r	μs		0.5		
Frequency bandwidth(-3dB)	BW	kHz		150		

CM5A H21 SERIES

Dimensions (in mm. 1 mm = 0.0394 inch)

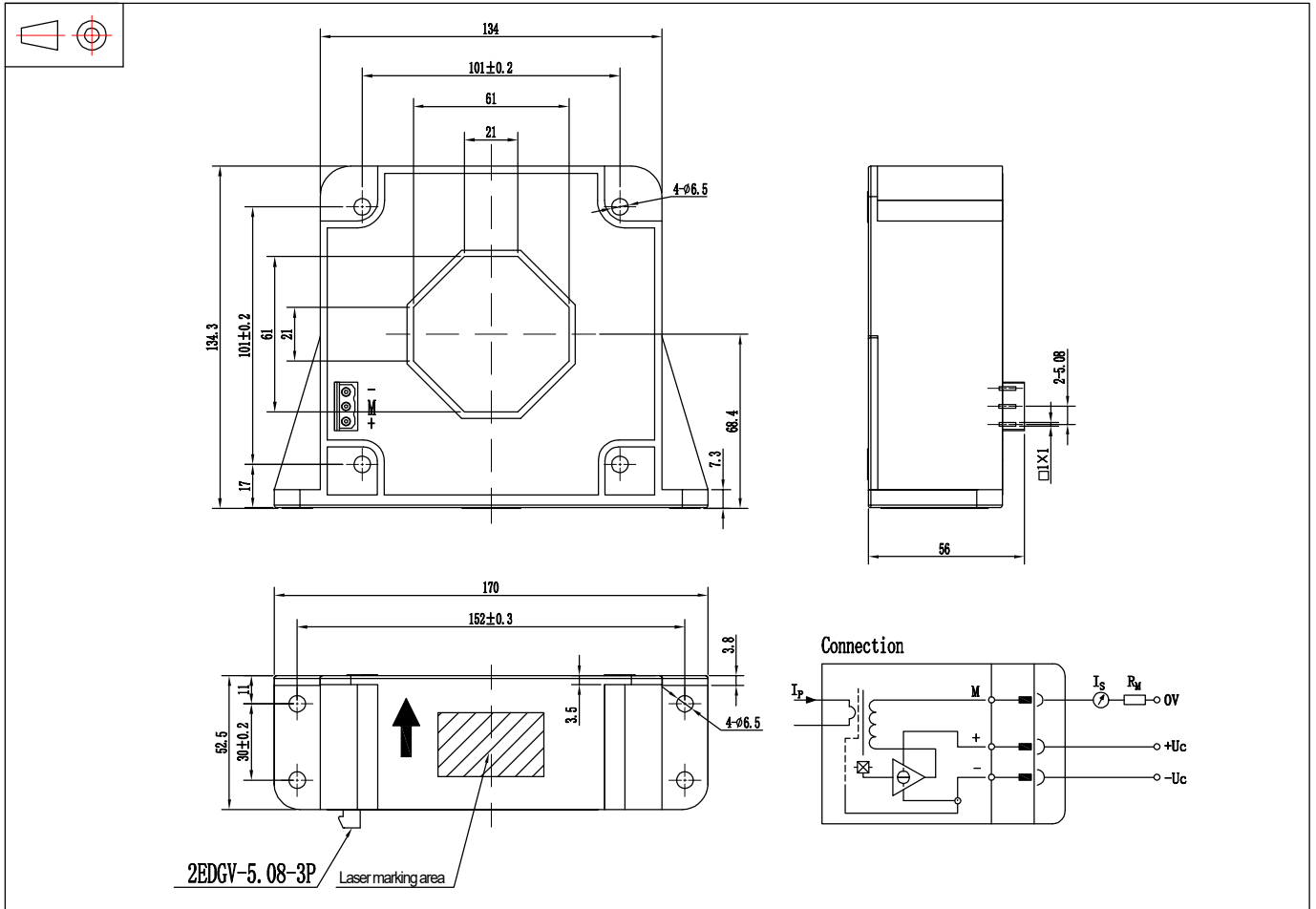

Mechanical characteristics

◇ General tolerance	±0.5 mm
◇ Primary hole	Φ57.5mm
or	61mm×21mm
◇ Connection of secondary	2EDGV-5.08-3P
◇ Transduce vertical fastening	4pc Φ6.5mm through-hole 4pc M6 metal screws
Recommended fastening torque	5.5 N•m (±10%)
◇ Transduce horizontal fastening	4pc Φ6.5mm through-hole 4pc M6 metal screws
Recommended fastening torque	5.5 N•m (±10%)

Remarks

- ◇ I_S and I_P are in the same direction, when I_P flows in the direction of arrow.
- ◇ Temperature of the primary conductor should not exceed 100°C.
- ◇ For security, do not install a current sensor with primary current or secondary power supply.

This is a standard model. For different applications (measurement, secondary connections...), please contact CHIPSENSE.